

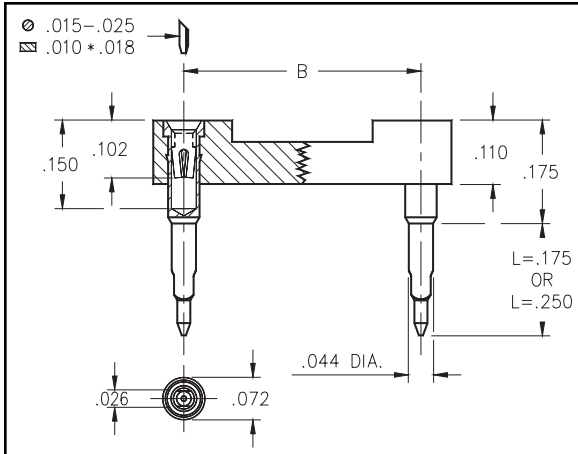

DUAL-IN-LINE SOCKETS Solderless Press-Fit Open Frame

Series 104



- Designed for solderless press-fit into plated thru-holes.
- Pin lengths are suitable for .062" and .093"-.125" thick panels.
- Required plated thru-hole is .036"-.041". Use a 1.1mm drill prior to plating.
- Series 104 use MM #0477 or MM #0478 pins with a BeCu #30 contact, rated at 3 amps. See page 131 for details.
- Insulators are high temperature thermoplastic.

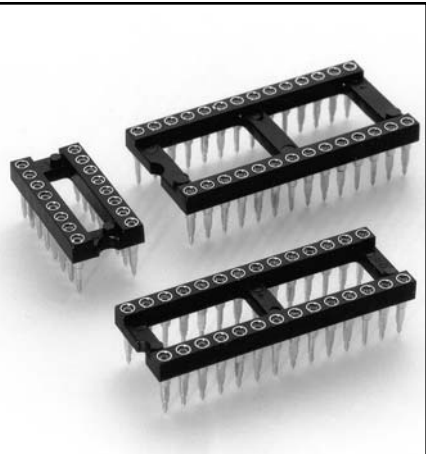

Total number of pins				Quantity per tube	Ordering Information		
	A	B	C		L = .175 (for .062 thick panel)	L = .250 (for .125 thick panel)	
	10	0.5	0.2		0.3	40	
4	0.2	0.3	0.4	102	104-13-304-41-770000	104-13-304-41-780000	
6	0.3	0.3	0.4	67	104-13-306-41-770000	104-13-306-41-780000	
8	0.4	0.3	0.4	50	104-13-308-41-770000	104-13-308-41-780000	
10	0.5	0.3	0.4	40	104-13-310-41-770000	104-13-310-41-780000	
14	0.7	0.3	0.4	28	104-13-314-41-770000	104-13-314-41-780000	
16	0.8	0.3	0.4	25	104-13-316-41-770000	104-13-316-41-780000	
18	0.9	0.3	0.4	22	104-13-318-41-770000	104-13-318-41-780000	
20	1.0	0.3	0.4	20	104-13-320-41-770000	104-13-320-41-780000	
22	1.1	0.3	0.4	18	104-13-322-41-770000	104-13-322-41-780000	
24	1.2	0.3	0.4	16	104-13-324-41-770000	104-13-324-41-780000	
28	1.4	0.3	0.4	14	104-13-328-41-770000	104-13-328-41-780000	
20	1.0	0.4	0.5	20	104-13-420-41-770000	104-13-420-41-780000	
22	1.1	0.4	0.5	18	104-13-422-41-770000	104-13-422-41-780000	
24	1.2	0.4	0.5	16	104-13-424-41-770000	104-13-424-41-780000	
28	1.4	0.4	0.5	14	104-13-428-41-770000	104-13-428-41-780000	
32	1.6	0.4	0.5	12	104-13-432-41-770000	104-13-432-41-780000	
24	1.2	0.6	0.7	16	104-13-624-41-770000	104-13-624-41-780000	
28	1.4	0.6	0.7	14	104-13-628-41-770000	104-13-628-41-780000	
32	1.6	0.6	0.7	12	104-13-632-41-770000	104-13-632-41-780000	
36	1.8	0.6	0.7	11	104-13-636-41-770000	104-13-636-41-780000	
40	2.0	0.6	0.7	10	104-13-640-41-770000	104-13-640-41-780000	
42	2.1	0.6	0.7	9	104-13-642-41-770000	104-13-642-41-780000	
48	2.4	0.6	0.7	8	104-13-648-41-770000	104-13-648-41-780000	
50	2.5	0.6	0.7	8	104-13-650-41-770000	104-13-650-41-780000	
52	2.6	0.6	0.7	7	104-13-652-41-770000	104-13-652-41-780000	
50	2.5	0.9	1.0	8	104-13-950-41-770000	104-13-950-41-780000	
52	2.6	0.9	1.0	7	104-13-952-41-770000	104-13-952-41-780000	
64	3.2	0.9	1.0	6	104-13-964-41-770000	104-13-964-41-780000	

For RoHS compliance select plating code.

XX= Plating Code
See Below

PLATING CODE XX=	13						
Sleeve (Pin)	10μ" Au						
Contact (Clip)	30μ" Au						